

Dating Methods of Pleistocene Deposits and Their Problems II. Uranium-Series Disequilibrium Dating

Henry P. Schwarcz

Volume 5, numéro 4, novembre 1978

URI : https://id.erudit.org/iderudit/geocan5_4art02

[Aller au sommaire du numéro](#)

Éditeur(s)

The Geological Association of Canada

ISSN

0315-0941 (imprimé)

1911-4850 (numérique)

[Découvrir la revue](#)

Citer cet article

Schwarcz, H. P. (1978). Dating Methods of Pleistocene Deposits and Their Problems II. Uranium-Series Disequilibrium Dating. *Geoscience Canada*, 5(4), 184-188.

Résumé de l'article

U-series dating makes use of the tendency of the short-lived daughters of ^{238}U and ^{235}U to be chemically separated from their parents during sedimentary processes. Ages of samples are determined either from the decay of initial excess of daughter (Daughter Excess, DE, dating) or growth of initially deficient daughter (DD) into secular equilibrium with the parent. DE dating is applicable to marine sediments where initial excesses of ^{210}Th and ^{231}Pa are observed. DD dating is useful on chemically precipitated CaCO_3 and some biogenic carbonates. By DD dating of travertines associated with various types of geomorphic features, absolute dates for the evolution of land-forms through the Quaternary can be obtained. DD dated speleothems also yield stable isotopic records of past climate.



Dating Methods of Pleistocene Deposits and Their Problems II. Uranium-Series Disequilibrium Dating

Henry P. Schwarcz
Department of Geology
McMaster University
Hamilton, Ontario L8S 4M1

Abstract

U-series dating makes use of the tendency of the short-lived daughters of ^{238}U and ^{235}U to be chemically separated from their parents during sedimentary processes. Ages of samples are determined either from the decay of initial excess of daughter (Daughter Excess, DE, dating) or growth of initially deficient daughter (DD) into secular equilibrium with the parent. DE dating is applicable to marine sediments where initial excesses of ^{230}Th and ^{231}Pa are observed. DD dating is useful on chemically precipitated CaCO_3 and some biogenic carbonates. By DD dating of travertines associated with various types of geomorphic features, absolute dates for the evolution of landforms through the Quaternary can be obtained. DD dated speleothems also yield stable isotopic records of past climate.

Introduction

Uranium series dating is based on the measurement of the relative radioactivities (disintegrations per unit time

per gram of sample) of uranium and its daughter isotopes. The basic principles are as follows:

1) In any natural material which contains uranium, and which has been undisturbed for a few million years, the activities of the daughters of uranium will equal the activities of the respective parent uranium isotopes. We describe such a sample as being in a state of secular equilibrium with respect to the uranium decay series (Fig. 1).

2) When a sedimentary deposit is formed, there occur various geochemical processes capable of separating the parent U isotopes from some of their daughter isotopes. Thus, a state of disequilibrium between parent and daughter is initiated.

3) If, subsequent to deposition the sediment is left undisturbed and not subject to diagenetic changes or other processes that could cause migration of radioisotopes into or out of the sediment, then at some subsequent

time it is possible to determine the date of deposition by measuring the extent to which the sediment has returned to a state of secular equilibrium.

There are two general cases that are commonly considered. First, the parent isotope may be deposited without any of its daughters, or a daughter deficiency or known extent may be established at the time of deposition. This is called daughter deficiency (DD) dating; age is determined from the extent of growth of the daughter into equilibrium with its parent. The principal examples of this class of methods are $^{230}\text{Th}/^{234}\text{U}$ and $^{231}\text{Pa}/^{235}\text{U}$ dating of carbonates (Fig. 2). Uranium is relatively soluble in water as carbonate and phosphate complexes of the uranyl (UO_2^{2+}) ion, whereas both thorium and protactinium are quite insoluble in sea-water and fresh-water, and are quickly precipitated out or adsorbed onto clay minerals after they are produced by decay of uranium. Therefore biogenic and chemically precipitated calcium carbonate are commonly deposited with 0.1 to 5 ppm uranium and no common thorium. They are thus ideally suited for this type of dating, since the $^{230}\text{Th}/^{234}\text{U}$ activity ratio is initially zero and grows with time to a limit of 1.0. If ^{230}Th had been initially present as a contaminant in the sample, it would normally have been accompanied by long-lived ^{232}Th . The abundance of ^{232}Th can sometimes be used to correct for initial ^{230}Th (Kaufman, 1971).

The second class of methods are the daughter excess (DE) techniques in which the daughter nuclide is initially present in excess of the amount of its parent. The main examples of this are the use of ^{230}Th and ^{231}Pa in the dating of deep sea sediments. Uranium-234 is present in sea water in slight excess with respect to ^{238}U ; attempts have been made to use this disequilibrium in order to date corals (Thurber *et al.*, 1965).

The details of the methods of age determination have recently been summarized by Ku (1976). Basically, U, Th or other nuclides are chemically extracted from the sample, purified, and their activities are determined using alpha-particle spectrometry or

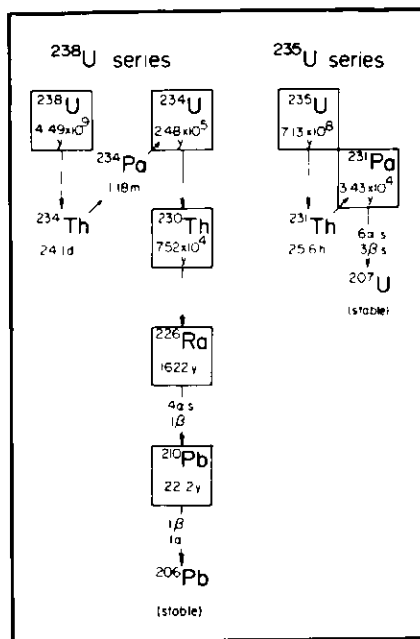

Figure 1

The radioactive decay series for ^{238}U and ^{235}U . The longer-lived isotopes of interest in this paper are outlined in boxes. Note that the activity of ^{235}U and its daughters is $\frac{1}{2}$ that of the ^{238}U -series isotopes. ^{210}Pb has been used in dating of recent sediments. ^{226}Ra is generally expected to be in secular equilibrium with ^{230}Th and can be used as an alternative measure of the latter's abundance

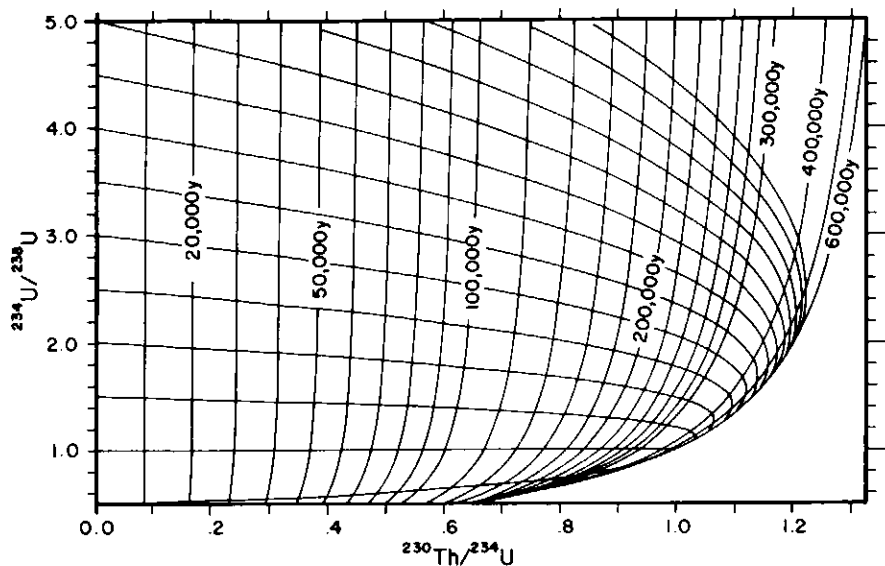

Figure 2
Relation between $^{234}\text{U}/^{238}\text{U}$ and $^{230}\text{Th}/^{234}\text{U}$ ratios for closed systems initially free of ^{230}Th . The subhorizontal curves are decay

paths for samples initially deposited with $^{234}\text{U}/^{238}\text{U}$ ratios equal to left-hand ($^{230}\text{Th}/^{234}\text{U}=0$) intercepts. The steep curves are isochrons, in years.

beta counters. Isotopic spikes are used to correct for the variable chemical yield of the different nuclides. The purpose of this paper is to describe the proven and potential application of these methods to the dating of continental and marine Quaternary events.

Application to the Quaternary

Geochronologists are interested in extending the time scale for climatic and geological events backwards beyond the range accessible to the more conventional methods of ^{14}C dating. In principle, U-series dating allows us to date suitable deposits whose ages range from as young as a few thousand years to as old as 500,000 years (for the $^{230}\text{Th}/^{234}\text{U}$ method).

1) Continental deposits. The main questions which geologists have raised about the evolution of the surface of the earth during the last few hundred thousand years relate to the intense changes in climate that have accompanied continental glaciation. Some of these changes have left records which are datable by the methods of disequilibrium dating. Unfortunately the most direct evidence, namely the deposits left by retreating glaciers are not datable except in fortuitous instances.

Chemically precipitated deposits of calcium carbonate can be dated by DD methods. Such deposits commonly contain traces of uranium but essentially no thorium since the latter element is relatively insoluble in ground and stream waters. The deposits may be superimposed on alluvial terraces which have themselves been formed by changes in supply of sediment or water associated with glacial or fluvial cycles. Furthermore, the activity of the stream or spring itself, especially in semi-arid or arid terranes, may be tied to the occurrence of higher rainfalls during pluvials. For example, in the Negev Desert, Israel, many fossil spring deposits exist where today no spring activity is observed; these tufa mounds are thought to date to a wetter period in the climatic cycle of that region. In the upper Danube valley in Hungary there are a series of travertine beds at successively higher levels above the present valley floor, elevated by uplift of the Buda hills. Th-230/U-234 dates on some of these travertines confirm that successively higher deposits are progressively older (Pécsi, 1973). Work in my laboratory is under way to date travertines in the Hot Springs district of central Wyoming, where river terraces whose deposition can be tied with

glacial events, have been encrusted with travertine mounds by the action of hot springs (G. Richmond, pers. commun., 1977).

Another type of chemical carbonate deposit is speleothem, formed by seepage waters in karstic caves. Such deposits, like spring-deposited travertines, contain traces of uranium in the calcite or aragonite crystals, but are essentially free of thorium or protactinium at the time of deposition. Unlike spring deposits which are subaerial and therefore subject to contamination by dust and alluvial detritus, cave deposits are generally quite pure. Even though they have been subjected to long-term showering by the same waters which originally deposited them, stalagmites and flowstones of caves appear to behave, in general, like closed systems with respect to migration of U and its daughters (Gascoyne *et al.*, 1978). Paleoclimatic information can be obtained from such deposits by study of their stable isotopic composition and that of the fluid inclusions of seepage water trapped in them during growth (Hendy, 1971; Schwarcz *et al.*, 1976; Harmon *et al.*, 1978a). During lowering of base level in the surrounding terrane, watertables are lowered, draining phreatic passages and allowing speleothem deposition to begin in them. Th/U dates on these oldest deposits can give information about the rate of downcutting of the adjacent river valleys (Ford *et al.*, 1972; Atkinson *et al.*, 1978). Where alluvial deposits have accumulated in the caves during periods of higher-than-average stream flow, subsequent incrustations of speleothem allows these deposits to be dated; in some cases these flood events may correlate with melt-water flow from nearby glaciers or increased rainfall during pluvials.

In alpine caves during glacial periods the soil is generally frozen to a considerable depth. Therefore, percolation of recharge waters ceases and no speleothem growth occurs. Harmon *et al.* (1977) have shown that the time of the last two interglacials in the Rocky Mountains can be defined on the basis of the distribution of ages of speleothems from caves in the Western U.S. and Canada (Fig. 3).

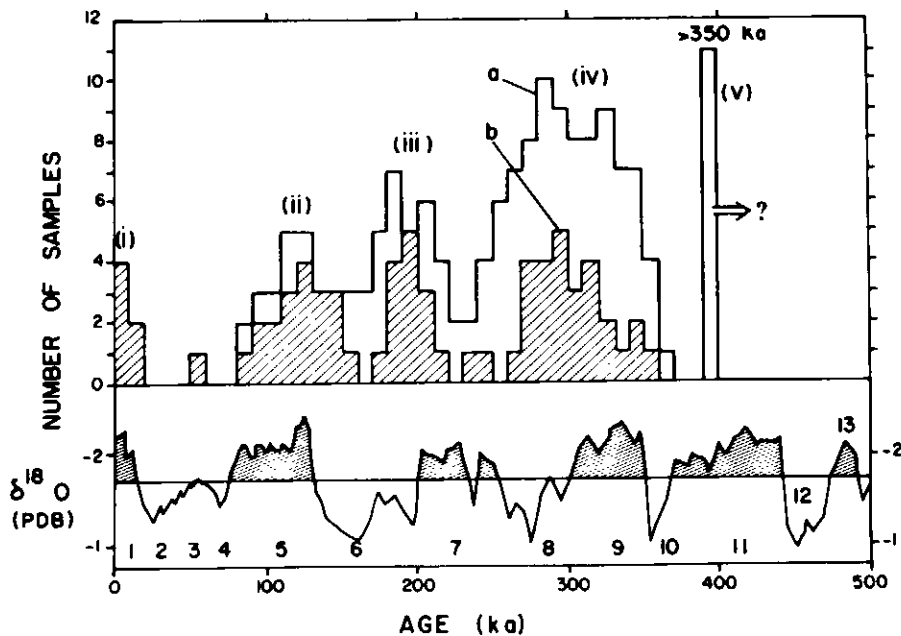

Figure 3

Histogram of cumulative data on growth periods of speleothems (stalagmites, flowstones, etc.) from caves in the Rocky and Mackenzie Mountains, U.S. and Canada. Curve 'a' represents the number of samples whose observed or extrapolated growth period, plus or minus one standard deviation, falls within the given 10⁴ year interval; curve 'b' shows the number of

samples whose growth periods lie within the 10⁴ year interval neglecting errors in age determination. For comparison at bottom is shown the δ¹⁸O record for planktonic foraminifera in deep-sea core V-28-238 (Shackleton and Opdyke, 1973). The shaded portions represent periods of low global ice volume, i.e., interstadials and interglacials (from Harmon et al., 1977).

Where saline lakes have receded from former, higher levels associated with pluvial periods, the high-lake stands can be dated through U-series dating of calcareous tufas or marls left by the higher lake stands. Kaufman and Broecker (1965) applied this method with limited success to the deposits of extinct Lakes Bonneville and Lahontan; later Kaufman (1971) was more successful in dating the Lisan series of marls in the Dead Sea region of Israel. The marls were highly contaminated with common thorium but Kaufman was able to correct for this by extrapolation on plots of $^{230}\text{Th}/^{234}\text{U}$ vs $^{232}\text{Th}/^{234}\text{U}$ to find uncontaminated $^{230}\text{Th}/^{234}\text{U}$ values. Closely related to such surface travertines are calcareous crusts formed on top of and inside of soil profiles in arid regions. If the soil does not contain clastic particles of limestone or dolomite (which would have an apparently infinite U-disequilibrium age) then the carbonate formed in such soils can be dated by U-series methods (Ku, 1975). Unfortunately, there will gener-

ally be a rather large contaminant of ^{230}Th leached from clays and other non-carbonate minerals in the soil during analysis of the acid soluble carbonate fraction of the soil. Some archaeological sites can be dated by U-series disequilibrium methods. Skeletal remains or other traces of human activity may be embedded in travertine, either in the entrance facies of caves where men sought shelter, or in spring deposits which were visited by early hominids. These deposits can in some instances be dated by the DD methods described above (Schwarcz, 1977; Turekian and Nelson, 1976).

Various attempts have been made to date molluscs, both fresh-water and marine, by DD methods. The assumption that molluscan carbonates are deposited free of common Th can easily be verified with modern shells. It has been found, however, that the uranium content of such shells increases markedly during diagenesis and burial of the shells, from initial values of around 0.1 ppm to values of more than 2 ppm in fossil shells

(Kaufman et al., 1971). Although most of this increase happens shortly after burial, this change in U content suggests that molluscan carbonate does not act as a closed system with regard to radioisotope migration. Indeed, great discrepancies between $^{230}\text{Th}/^{234}\text{U}$ and ^{14}C dates on mollusc shells are commonly found, and much doubt has been cast on the applicability of DD methods (Kaufman et al., 1971). Similar problems arise in the dating of vertebrate bones. It has long been known that the U content of bones gradually increases during burial (Oakley, 1970). While various open system models for dating of such materials such as that of Szabo and Rosholt (1969) could be applied, the initial work of Cherdyntsev (1956) indicates that there is serious question about the method's reliability. Although a number of dates have been obtained including an estimate of the time of occupation of the Swanscombe site (Szabo and Collins, 1975) such dates should be looked upon with great skepticism until the evident problems in the dating of bones have been resolved.

2) *Marine deposits.* The most generally accepted absolute time scale for the pre- ^{14}C part of the Quaternary (the part older than 50,000 B.P.) is that obtained from the study of deep-sea sediment cores, and in particular correlated variations in the abundances of various planktonic fauna and flora, which are taken as indications of changes in sea-surface temperature (CLIMAP, 1976). Absolute rates of sedimentation have been determined for the most part by DE methods (e.g., Broecker and Ku, 1977). The oxygen isotope record of planktonic foraminifera is principally a record of changes in continental ice volume (Shackleton and Opdyke, 1974) and therefore can be used as a stratigraphic marker whose age can be calibrated in the relatively few DE-dated cores. Some of these inferred glacial events can be correlated with the continental glacial record (Shackleton, 1975).

Another consequence of glacial growth and retreat is change in sea level. Past high sea levels can be determined on tectonically stable coastlines from the elevation of raised

coral reefs. Corals still composed of unrecrystallized aragonite, can be dated by DD methods (Barnes *et al.*, 1956), and a time scale can be seen better on coastlines subject to steady tectonic uplift such as New Guinea (Bloom *et al.*, 1974). Molluscs in raised beach deposits, have also been dated to yield information on interglacial high sea-stands, for example by Stearns and Thurber (1965) in the Mediterranean, critically reviewed by Butzer (1975). Low sea stands can be obtained by dating submerged speleothems in caves which have been "drowned" by post-glacial eustatic sea-level rise (Spalding and Mathews, 1972; Harmon *et al.*, 1978b). The submerged speleothems give minimum dates for the time of recession of sea level below the depth from which they are recovered.

Concluding Remarks

In this brief summary I have attempted not only to review some of the past achievements of U-series dating, but to point out possible future applications in settings not yet fully explored. Besides those methods mentioned above, it is worth noting that disequilibrium between ^{234}U and ^{238}U in travertines formed in terrestrial environments can be very great, with $^{234}\text{U}/^{238}\text{U}$ ratios ranging up to 6 (Harmon and Schwarcz, unpubl.). The possibility has been noted of using the decay of this disequilibrium as a dating tool (G. Thompson *et al.*, 1975) although it must be approached with great caution (Harmon *et al.*, 1978c). It is hoped that future improvements can be made in the application of disequilibrium methods to molluscs and vertebrate bones, as these are two types of materials which would appear at first sight to be promising candidates, but which have led to much frustrateochronologists.

References

- Atkinson, T.C., Harmon, R.S., Smart, P.L. and Waltham, A.C., 1978, Paleoclimatic and geomorphic implications of $^{230}\text{Th}/^{234}\text{U}$ dates on speleothems from Britain: *Nature*, v. 272, p. 24-28.
- Barnes, J., Lang, E.J., and Potratz, H.A., 1956, Ratio of ionium to uranium in coral limestone: *Science*, v. 124, p. 175-176.
- Bloom, A.L., Broecker, W., Chappell, J.M.A., Matthews, R.K. and Mesolella, K.J., 1974, Quaternary sea-level fluctuations on a tectonic coast: new $^{230}\text{Th}/^{234}\text{U}$ data from the Huon Peninsula, New Guinea: *Quat. Res.*, v. 4, p. 185-205.
- Broecker, W. and Ku, T.L., 1969, Caribbean cores P6304-8 and P6404-9: New analysis of absolute chronology: *Science*, v. 166, p. 404-406.
- Butzer, K., 1975, Pleistocene littoral-sedimentary cycles of the Mediterranean basin; a Mallorquin view: in K.W. Butzer *et al.*, eds., *After the Australopithecines: The Hague, Mouton*, p. 25-71.
- Cherdyntsev, V., 1956, Determination of the absolute age of the Paleolithic: *Sov. Arkheol.*, v. 25, p. 64-86.
- CLIMAP, 1976, The surface of the ice age Earth: *Science*, v. 191, p. 1131-1137.
- Ford, D.C., Thompson, P. and Schwarcz, H.P., 1972, Dating cave calcite deposits by the uranium disequilibrium method: some preliminary results from Crowsnest Pass, Alberta: in E. Yatsu, and A. Falconer, eds., *Research Methods in Pleistocene Geomorphology: Univ. Guelph, Guelph, Ontario*, p. 247-255.
- Gascoyne, M., Schwarcz, H.P. and Ford, D.C., 1978, Uranium series dating and stable isotope studies of speleothem: Part I, Theory and techniques: *British Cave Research Assoc., Trans.*, in press.
- Harmon, R.S., Ford, D.C., and Schwarcz, H.P., 1977, Interglacial chronology of the Rocky and Mackenzie Mountains based upon ^{230}Th - ^{234}U dating of calcite speleothems: *Can. Jour. Earth Sci.*, v. 14, p. 2543-2552.
- Harmon, R.S., Thompson, P., Schwarcz, H.P. and Ford, D.C., 1978a, Late Pleistocene paleoclimates of North America as inferred from stable isotope studies of speleothems: *Quat. Res.*, v. 9, p. 54-70.
- Harmon, R.S., Schwarcz, H.P., and Ford, D.C., 1978b, Late Pleistocene sea level history of Bermuda: *Quat. Res.*, v. 9, p. 205-218.
- Harmon, R.S., Schwarcz, H.P., Thompson, P. and Ford, D.C., 1978c, Critical comments on "Uranium series dating of stalagmites from Blanchard Springs Caverns, Arkansas, U.S.A.": *Geochim. Cosmochim. Acta*, v. 42, p. 433-437.
- Hendy, C., 1971, The isotopic geochemistry of speleothems, I: The calculation of the effects of different modes of formation on the isotopic composition of speleothems and their applicability as paleoclimate indicators: *Geochim. Cosmochim. Acta*, v. 35, p. 801-824.
- Kaufman, A., and Broecker, W., 1965, Comparison of Th^{230} and C^{14} ages for carbonate materials from Lakes Lahontan and Bonneville: *Jour. Geophys. Res.*, v. 70, p. 4039-4054.
- Kaufman, A., 1971, U-series dating of Dead Sea Basin carbonates: *Geochim. Cosmochim. Acta*, v. 35, p. 1269-1281.
- Kaufman, A., Broecker, W., Ku, T.L. and Thurber, D.L., 1971, The status of U-series methods of mollusk dating: *Geochim. Cosmochim. Acta*, v. 35, p. 1155-1183.
- Ku, T.L., 1975, Dating of caliche: Presented at Penrose Conference, 1975.
- Ku, T.L., 1976, The uranium-series methods of age determination: *Ann. Rev. Earth Planet. Sci.*, v. 4, p. 347-379.
- Oakley, K., 1970, Analytical methods of dating bones: in D. Brothwell and E. Higgs, eds., *Science in Archaeology: New York, Praeger*, p. 23-34.
- Pecci, Marton, 1973, Geomorphological position and absolute age of the lower Paleolithic site at Vértesszöllös, Hungary: *Földrajzi Közlemények*, no. 2, p. 109-119.
- Schwarcz, H.P., Harmon, R.S., Thompson, P. and Ford, D.C., 1976, Stable isotope studies of fluid inclusions in speleothems and their paleoclimatic significance: *Geochim. Coschim. Acta*, v. 40, p. 657-665.
- Schwarcz, H.P., 1977, Uranium series dating of travertine from Paleolithic sites X INQUA Congress, Birmingham, Abstracts, p. 409.
- Shackleton, N. and Opdyke, N., 1973, Oxygen isotope and paleomagnetic stratigraphy of equatorial Pacific core V28-238: Oxygen isotope temperature and ice volumes on a 10^5 and 10^6 year scale: *Quat. Res.*, v. 3, p. 39-55.

Shackleton, N., 1975, The stratigraphic record of deep sea cores and its implications for the assessment of glacials, interglacials, stadials and interstadials in the mid-Pleistocene: *in After the Australopithecines*, K.W. Butzer and G. Isaac, eds., p. 1-24.

Spalding, R.F. and Matthews, T.D., 1972, Submerged stalagmites from caves in the Bahamas: Indicators of low sea-level stand. *Quat Res.* v. 2, p. 470-472.

Stearns, C.E. and Thurber, D.L., 1965, $\text{Th}^{230}/\text{U}^{234}$ dates of late Pleistocene marine fossils from the Mediterranean and Moroccan littorals: *Quaternaria*, v. 7, p. 29-42.

Szabo, B. and Rosholt, J., 1969, Uranium-series dating of Pleistocene molluscan shells from southern California: an open system model: *Jour. Geophys. Res.*, v. 74, p. 3253-3260

Szabo, B., and Collins, D., 1975, Ages of fossil bones from British interglacial sites: *Nature*, v. 254, p. 680-682.

Thompson, G., Lumsden, D.N., Walker, R.L. and Carter, J.A., 1975, Uranium series dating of stalagmites from Blanchard Springs Caverns, U.S.A. *Geochim. Cosmochim. Acta*, v. 39, p. 1211-1218.

Thurber, D.L., Broecker, W.S., Blanchard, R.L. and Potratz, H.A., 1965, Uranium-series ages of Pacific atoll coral. *Science*, v. 149, p. 55-58.

Turekian, K.K. and Nelson, E., 1976, Uranium decay series dating of the travertines of Caune de L'Arage (France). *Union Intern. Sci. Prehist. et Protohist, IX Congress (Nice): Proceedings, Colloque I*, p. 171-179

MS received June 20, 1978