

The Standard Data and their Limitations Les temps prédéterminés et leurs limitations

Jean-Paul Deschênes

Volume 12, numéro 3, juillet 1957

URI : <https://id.erudit.org/iderudit/1022566ar>

DOI : <https://doi.org/10.7202/1022566ar>

[Aller au sommaire du numéro](#)

Éditeur(s)

Département des relations industrielles de l'Université Laval

ISSN

0034-379X (imprimé)

1703-8138 (numérique)

[Découvrir la revue](#)

Citer cet article

Deschênes, J.-P. (1957). The Standard Data and their Limitations. *Relations industrielles / Industrial Relations*, 12(3), 211–222.

<https://doi.org/10.7202/1022566ar>

Résumé de l'article

La pratique de déterminer de façon exacte le temps requis pour accomplir une tâche est de plus en plus répandue dans nos manufactures modernes et leur usage est des plus variés. Une méthode employée pour déterminer ce temps que prend l'accomplissement d'une tâche est l'usage des temps déterminés par les ingénieurs industriels et qui sont censés donner le temps exact requis pour l'accomplissement des éléments les plus simples d'une opération. C'est cette méthode qui fera l'objet de notre critique.

La façon générale de déterminer le temps requis pour accomplir une tâche est la suivante. La tâche est démembrée dans ses opérations les plus simples et le temps de ces opérations est enregistré. Mais comme ce temps varie d'un individu à l'autre, on en choisit un jugé représentatif, on le multiplie par un facteur appelé facteur de performance et on obtient ainsi un temps de base. A ce temps de base on ajoute un certain pourcentage tenant compte de la fatigue, des délais inévitables, etc., et on obtient le temps standard de l'opération.

Le jugement est nécessaire pour déterminer le facteur de performance, et comme les ingénieurs y voient une source d'erreur, on a tenté de tabuler les temps requis pour accomplir les éléments les plus simples d'une opération et qu'on appelle therbligs.

Il va s'en dire que ces temps calculés à l'avance sont sujets à la question suivante: Sont-ils représentatifs? Ordinairement ces temps sont obtenus dans un laboratoire où les conditions sont différentes de celles d'un atelier et les individus analysés sont trop peu nombreux pour représenter une population entière. De plus, ils sont rarement choisis au hasard.

LE RYTHME

En employant ces temps prédéterminés il faut présumer que le rythme de travail n'est pas personnel ou du moins qu'on peut l'imposer. Dans une expérience conduite par Barnes et Mundel, on a réalisé que plus l'opération est longue, plus la différence de temps entre les opérateurs est minime, et que plus l'opération est courte, plus la différence est marquée.

On découvre par ailleurs que les éléments d'une opération influent les uns sur les autres, qu'un élément dépend de celui qui le précède et qu'à son tour il influencera le suivant. C'est pourquoi il n'est pas justifiable de prendre ces temps prédéterminés et donnés dans des tables, de les additionner et de déterminer ainsi le temps requis pour accomplir une tâche.

En conclusion, disons que le temps requis pour accomplir une tâche dépend:

1. de l'individu lui-même qui l'accomplit et,
2. de l'ordre dans lequel les éléments d'opération apparaissent dans la tâche.

De plus, certaines expériences nous amènent à conclure que non seulement la relation des éléments varient d'un individu à l'autre mais aussi chez le même individu.

Ces temps prédéterminés peuvent quand même être d'une grande utilité pour établir des contrôles et améliorer le processus de la production, mais ce n'est pas rendre justice à l'employé que de s'en servir pour établir un système de rémunération selon la production accomplie.

The Standard Data and their Limitations

Jean-Paul Deschênes

In this article, the author considers the possibility of using standard data in setting standard times to perform a specific job. Where and when can those data be used? Before answering these questions, he describes the procedure to be followed in applying this method and insists on the limitations of its application, taking into account the data themselves, the operator and the study man.

The determination of the accurate time needed to perform a job is widely used to-day and its applications has expanded to include the following uses:

To reduce costs; to improve methods; as a basis for wage incentives; as a basis for time estimates on future work; to increase the production rate; as a basis for production planning standards; plant layout; to balance working force and available work; to determine plant and machine capacity; to aid in purchasing new equipment; to reduce fatigue; to improve tools, jigs and equipment; to improve the quality of work (indirectly); as an aid in instructing the workers; as a basis for standard cost; as a basis for labor performance reports; as a basis for balancing work on line or progressive assemblies.¹

One method used in determining the time to perform a job is the application of standard data.

Because workers do not have the same ability in performing an operation, or any kind of job, it is the task of the time study man to establish a time value which will fairly represent the abilities of the

DESCHENES, JEAN-PAUL, B.A., Master in Social Sciences, (Laval University), Master of Science in Engineering (Business and Industrial Management), Johns Hopkins University (September 1957); Professor in the Department of Industrial Relations, Laval University.

(1) ROBERT L. MORROW, *Time Study and Motion Economy*, The Ronald Press Company, New York, 1946, pp. 83-84.

majority of the people working on an operation.

It is obvious however that we seldom find an operator performing an operation in a standard time at a standard pace. Thus the time study man must select a time taken to perform an operation, and adjust this time, according to the normal performance concept, to get a base time.

This procedure is known as rating, and is calculated by multiplying the selected time by the performance factor. The standard time is obtained by adding to the Base Time a certain percentage of allowances for personal needs, fatigue and unavoidable delays.

$$\begin{aligned} \text{Selected time} \times \text{Performance Factor} &= \text{Base Time} \\ \text{Base Time} \times (1 \text{ plus } \% \text{ of Allowances}) &= \text{Standard Time} \end{aligned}$$

The method used in order to get the Base Time is performed in three steps, all of them involving judgement:

- 1—Select a time to perform an operation.
- 2—Compare this time with the Standard Base Time or Normal Performance.
- 3—Adjust the selected time so that it will represent Normal Performance.

It goes without saying that judgement is also used in determining the percentage of allowances.

Judgement being considered as a source of error and inaccuracy by time study men, many industrial engineers tried to make tables of the time required to perform the basic movements of any operation. In this article, we will study the possibility of using standard data in setting standard times.

Where and when can we use standard data: that is the question I would like to answer.

Standard data, to be used in a wage incentive system for example, must be representative. If, according to the standard data, the time required to perform an element of an operation is .00X of a minute, this time should be the mean of the universe.

Indeed we can safely assume that the distribution of the time required by the whole population to perform an element will approach a normal distribution and the average is a representative value. However, all the standard data available were obtained in *laboratory investigation* with a *very small sample* of the whole population *not chosen in a random manner*. If for example the result of an investigation is that the average time required to perform a movement of X inches is 0.004 of a minute, how can we know that this average is the average of the population?

Rhythm

Besides this fact that standard data can hardly be representative, we have to make many doubtful assumptions to attempt proving that standard data are the best way of establishing standard times.

First of all we have to assume that rhythm is not personal, or at least can be imposed to everybody, assuming again that there is one best method for everyone to perform an operation.

In an experiment conducted by Barnes and Mundel,² the operators had to take washers of different thicknesses from a small table and to carry them to another similar table 5 inches apart. For the simplest element,³ grasp the washer for example, the time required for this movement of 5 inches from one point to another with a washer thickness of 1/32 of an inch is .127 of a second for the fastest worker and .269 for the slowest. With a washer thickness of 1/8, the range is from .153 to .309. With 1/2, the range is between .129 and .218. Indeed, the ratio is about 2.1, which is supposed to be the ratio for

(2) MUNDEL, M.E. (with BARNES, R.M.), *A Study of Hand Notions Used in Small Assembly Work*, University of Iowa Studies in Engineering 1939. Bulletin No. 16; also *Iron Age*, Mar. 30, 1939, Vol. 143, pp. 32-37.

(3) Any manual work performed can be broken down into few elementary motions or very simple elements called "therbligs". Some of the eighteen therbligs generally accepted are:

- 1.—*Grasp*. Begins when hand or body member touches an object.
- 2.—*Position*. Begins when hand or body member causes part to begin to line up or locate.
- 3.—*Use*. Begins when hand or body member actually begins to manipulate tool or control, etc.

MARVIN E. MUNDEL, *Motion and Time Study*, Sec. edition, Prentice-Hall Inc., New York 1955.

the workers of American factories. The data given, however, are only medians and we can assume that the ratio would have been much greater dealing with true values.

In the same experiment we find that the difference among workers becomes less and less important as the time required to perform an element is greater. To illustrate that, here are some results of this experiment done with female operators.

The time is expressed in fraction of second

	<i>Grasp</i>	<i>Transport loaded & Position</i>	<i>Release load & Transport Empty</i>	<i>Total</i>
Operator 1	.148	.423	.366	.937
Operator 2	.50	.426	.485	.962

We start with a ratio of 3.1 and the total cycle is shorter for the one who took .148 of a second to grasp the washer.

In another experiment conducted by the same people, the results were about the same.

	<i>Select & Grasp</i>	<i>Transport empty</i>	<i>Total cycle</i>
Op. 1	.462	.81	1.023
Op. 2	.313	.91	.847
Op. 3	.518	.63	.926
Op. 4	.468	.20	.848
Op. 5	.386	.99	.904

Morrow, in his method called Synthetic Leveling, proposes the following procedure to get standard times: ⁴

- 1.—Take the time study as usual.
- 2.—Break it down into elements.
- 3.—Compare as many of these elements as possible with the pre-determined standard times to get the percentage of variations of the actual time from the standards.
- 4.—Apply the same percentage to other parts of this study for which predetermined standard data are not available.

(4) MORROW, R.L., *Time Study and Motion Economy*, New York, The Ronald Press Co., 1946.

Here is an example:

<i>Elements of motion</i>	<i>Standard times from standard date</i>	<i>Actual times</i>
Element no. 1	0.070	.069
Element no. 2	.102	.101
Element no. 3	X	.130
Element no. 4	X	.080
	$\frac{.070}{.069} = 101 + \%$	$\frac{.102}{.101} = 101 - \%$

So the rating factor is 1.01 and then, for nos. 3 & 4 we get .131 and .081.

“The application of such a procedure implies an assumption that, within limits, all manually controlled elements of a study are affected equally by variations in the operator’s skill, aptitude, pace, exertion, attitude, and the like.” However the results obtained from the study conducted by Barnes and Mundel show that there is no consistency in performing elements. One element might be fast, the next one might be slow.

Individual Rhythm is therefore an explanation of the different times required by operators to perform the same element of an operation. But I don’t think this is the only reason. Some other sources of variation, like physiological sources, psychological sources, etc., may interfere.

Physiological sources do not seem to be very important if we consider the results for the Hawthorne experiment when the observers studied the effect of illumination, humidity and rest periods on the output. The experiment, however, was conducted under special circumstances, in other words, the six operators worked in a special room, knew that they were the object of an investigation, were highly motivated, and consequently tried to react according to what they thought the observers were expecting.

Psychological Sources

Psychological sources are much more important. I have discussed a few moments ago the problem of rhythm and now we shall look the possibility of breaking down an operation into its fundamental elements

and then to sum the time required to perform each element, taking those times from standard data, in order to get the total cycle time.

Total Time and Individual Elements

This is one of the most important assumptions made by industrial engineers using standard data, that the time required to perform an operation is equal to the sum of the times required to perform each element of this operation.

Suppose for example that we have an operation called O, composed of 3 elements for which we have standard data. According to this assumption,

$$\begin{array}{rcl}
 \text{Element 1} & = & .00X \\
 \text{Element 2} & = & .00Y \\
 \text{Element 3} & = & .00Z \\
 \hline
 \text{Cycle} & = & .00\text{Total}
 \end{array}$$

Is this accurate? I have here two opposite statements concerning the concept of elements. The first one is by R. Olsen who comments this way about the elemental operation of Taylor.

“Like an element in chemistry, this was considered to be the finest breakdown possible. However, within a few years, Frank Gilbreth had further subdivided the elemental operation into fundamental motions, which he called therbligs. Again these were considered the finest possible subdivision. Yet, just as the chemist has found the elemental atom subdivided into protons and electrons, . . . so the industrial engineer has seen his therbligs further subdivided into “movements”, which . . . may be defined as muscular reaction required to physical and psychological make-up.”⁶

On the other hand, Farmer, a British psychologist, asserted that “the actual method finally adopted by the worker must be the one which he finds the most convenient; that is, the one best suited to is physical and psychological make-up.”⁶

(5) OLSEN, R.A., *Setting Time Standards Without A Stop Watch*, Factory Management and Maintenance, Vol. CIV, February 1946, p. 95.

(6) UHRBROCK, RICHARD STEPHEN, *A Psychologist Looks at Wage Incentives*, New York, American Management Association, 1935, p. 3.

Dewey, another psychologist, observed that there were no partitions between the activities of organisms; when an act displayed unity, that unity was functional: it had no existential separateness.

These statements from psychologists infer that therbligs are not grounded in the nature of things but are convenient devices for some practical purpose as stated by William Gomberg.⁷

Condemning this practice of using therbligs and consequently standard data to build up an operation, Myers observes that an individual is indivisible and that this procedure is no more effective than would be an attempt to build a new person by removing bodily organs where superior ones are discovered in another person and transplanting the better organs to the original person. The whole sense of pattern is lost.⁸

From these quotations the conclusion is obvious: an operation is not the sum of the elements which compose this operation because the individual is one, distinct from another individual, and the way he acts and reacts is his own. A pattern of elements might be the best one for one person and the worst for another one. Therefore, there is no best method.

Expressing the same idea in other terms, we can say that the time required to perform an element of an operation depends not only on the individual, but also on the position in which this element appears; that is, it is a function of the position in the sequence in which the element appears. This is indicated from the findings of Barnes and Mundel in their study of Simultaneous Hand Motions.⁹ It was found that the standard time for certain therbligs cannot be given (even for a specific operation) as independent values since they may be influenced by other elements in the cycle.

For example, one task consisted of the following elements: Pick up and Transport, Position, and insert pins into bushings with beveled holes. When the hole size was changed, 2 results were obtained. First, the time of the motions involved in picking up and transporting the pins was also changed. It should be stressed that the size of the

(7) GOMBERG, W., *A Trade Union Analysis of Time Study*, New York, Prentice-Hall, Inc., 1955, p. 120.

(8) GOMBERG, W., *Ibid.*, p. 122.

(9) MUNDEL, M.E., with BARNES, R.M., *A Study of Simultaneous Symmetrical Hand Motions*, University of Iowa, Studies in Engineering, 1939, Bulletin No. 17.

hole should not have affected the first element, according to the fundamental assumption of the standard method.

Here are some of the results:

Diameter of the hole: .20 inch.
 Clearance : .002 inch.

Transport loaded Position Assemble & disassemble

1 ¹⁰	Average	.311 sec.	.281	.190
2 ¹¹	Average	.304	.327	.327
3 ¹²	Average	.347	.290	.179
4 ¹³	Average	.369	.295	.176
5 ¹⁴	Average	.384	.485	.133

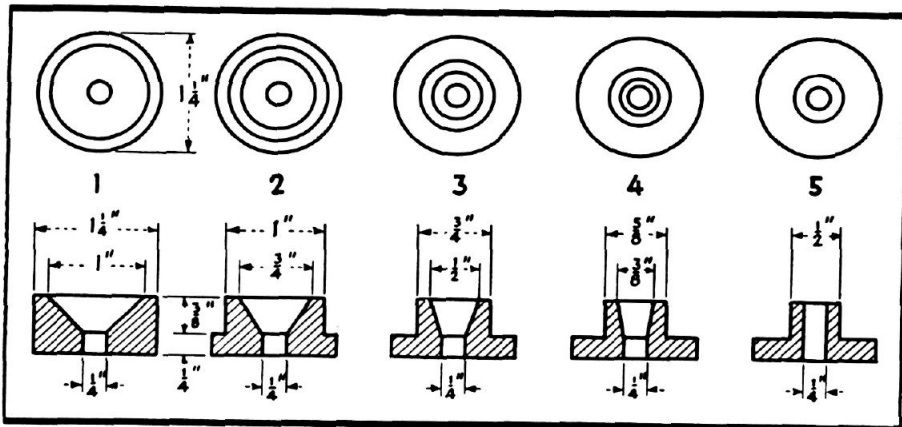
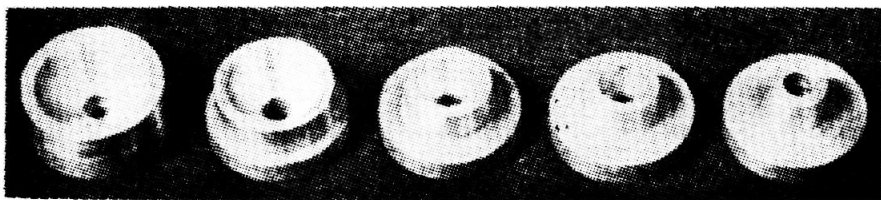

Figure 1. Two sets of bushings, one of which is shown in the top photograph, were used. For part *A* the diameter of the hole was 0.250 inch, which gave a clearance of 0.002 inch between pin and hole. For part *B* the diameter of the hole was 0.258 inch, which gave a clearance of 0.010 inch¹⁵.

- (10) 1 corresponds to 1 in the Figure below.
- (11) 2 corresponds to 2 in the Figure below.
- (12) 3 corresponds to 3 in the Figure below.
- (13) 4 corresponds to 4 in the Figure below.
- (14) 5 corresponds to 5 in the Figure below.
- (15) Figure from Study: *Motion and Time Study Applications*, Ralph M. Barnes, John Wiley & Sons Inc., New York, 1953, p. 41.

In an engineering factory, a girl inspector was gaging a job with the gage set to a tolerance of + or — 0.0005 inch. With a similar product, the gage setting was changed to a + or — .005 inch tolerance, and the following relative results were obtained.

	<i>.0005 Tol.</i>	<i>.005 Tolerance</i>
1—Pick up & Position job	0.55 sec.	0.40 sec.
2—Gage	1.20	0.70
3—Down job	0.45	0.35

Much the same kind of result is obtained if a light weight is substituted for a heavy weight while everything else in a simple motion cycle is kept constant.

	<i>Heavy (56 lbs)</i>	<i>Light (7 lbs)</i>
1—Walk to weight	3.5	2
2—Bend down & Grasp	2.	0.7
3—Straighten & walk	4.7	2.6

Here is another example. The job was a very delicate one consisting of machine-howing a part of an aircraft pump to + and — .0002 inch and measuring the job on a high grade measuring comparator. The idea was to put unskilled girls who knew nothing of the terrors of fine tolerance work on the job.

The comparative results were as follows:

	<i>Part times</i>	<i>Good %</i>
Skilled men	.32 sec.	81
Girls	.19 sec.	94

The job, the machine and the gage were the same as formerly. The difference was that the girls were told to work between certain marks on the comparator gage dial and the matter of tolerance was not mentioned.

Those experiments were conducted in laboratories with a few highly motivated people. Abruzzi, author of *Work Measurement*, conducted much more extensive studies covering many more cases and dealing with industrial operations performed under factory conditions by representative workers. The results were obtained by making comprehensive statistical tests.

The results conclusively demonstrated that elements were not independent. Two additional findings were:

1—The existence of independence depends on the number and the magnitude of the elements involved with different operators and even with the same operator.

Abruzzi's conclusions are:

a) A prolonged delay in one part of the cycle prompts the worker to exceed his usual pace in a subsequent part of the cycle.

b) Workers differ in the number, the type, and the duration of delays encountered.

c) Workers vary in the way in which they perform certain elements.

d) Many workers introduce extraneous elements into their work methods from time to time.

Abruzzi concludes: . . . "Each worker organizes operation elements into an integrated total pattern; he organizes the work method into a unified whole. This explains why the divisions between the various elements become somewhat artificial and difficult to distinguish. This implies, in turn, that many elements do not make up logical operation subdivisions."¹⁶

This evidence thus demonstrates that workers do not perform their work in terms of individual elements. Instead, they perform their work in terms of group elements, whose individual units are generally correlated.

Up to that point, I tried to analyze the limitations of standard data. Even considering many other aspects of the problem, such as individual rhythm, psychological and physiological factors, it is impossible in practice to determine the influence of each of those factors on the time required to perform one element or group of elements, since probably they are influenced by each other as elements are. If the time varies for the same element it is not because of the element itself, but because it is performed by an individual who puts on the job his complete personality, body and soul.

(16) ABRUZZI, A., *Work Measurement*, Columbia University Press, 1952, pp. 144 and sq.

Our general conclusion is that standard data are useless if they represent the time required to perform what industrial engineers call fundamental elements. An operation is not the sum of its elements, because its elements are related to each other and are influenced by each other. If we change the sequence of those elements, the whole pattern is changed and the time for the operation is not the same. In a very fast key topping experiment, the results showed that eliminating two or more of the movements did not reduce the cycle time as much as had been expected. The reason is simple: man is not a machine, and the way he reacts depend upon his personal factors.

Thus the unique problem of standard data for setting standard times as they are used now is the problem of dependence of elements.

Abruzzi suggests grouping 2 or 3 elements together and then taking the time required. But in doing so, each operation will have its own subgroups, and we go back to the old method.

Selected time X P.F. = B.T.

B.T. X (1 plus % allowances) = S.T.

From all the foregoing experiments and opinions, we may be a little skeptical concerning the use of standard data in time-study. According to many industrial engineers standard data have worked well in the plants where they have been applied. Was it because they are logical and based on true assumptions? It is doubtful.

As we saw, the worker tends to work faster to compensate for an element where he spent a longer time. He probably adapts himself not to the time set to perform each element, but rather to the time required to perform the operation as a whole. So, if the standard data seem to work, it is not because they are correct, but because the worker adapts himself to those standards. On the other hand, the allowances granted by the timestudy man might help the standard data to fit better.

However, their limitations being known, the standard data might be useful to set standard times where jobs change frequently, or to get a approximation of the cost of the product. In using it for wage incentive, we force the worker to a certain extent to change his natural movements for artificial ones.

SOMMAIRE

LES TEMPS PREDETERMINES ET LEURS LIMITATIONS

La pratique de déterminer de façon exacte le temps requis pour accomplir une tâche est de plus en plus répandue dans nos manufactures modernes et leur usage est des plus varié. Une méthode employée pour déterminer ce temps qui prend l'accomplissement d'une tâche est l'usage des temps déterminés par les ingénieurs industriels et qui sont censés donner le temps exact requis pour l'accomplissement des éléments les plus simples d'une opération. C'est cette méthode qui fera l'objet de notre critique.

La façon générale de déterminer le temps requis pour accomplir une tâche est la suivante. La tâche est démembrée dans ses opérations les plus simples et le temps de ces opérations est enregistré. Mais comme ce temps varie d'un individu à l'autre, on en choisit un jugé représentatif, on le multiplie par un facteur appelé facteur de performance et on obtient ainsi un temps de base. A ce temps de base on ajoute un certain pourcentage tenant compte de la fatigue, des délais inévitables, etc., et on obtient le temps standard de l'opération.

Le jugement est nécessaire pour déterminer le facteur de performance, et comme les ingénieurs y voient une source d'erreur, on a tenté de tabuler les temps requis pour accomplir les éléments les plus simples d'une opération et qu'on appelle *therbligs*.

Il va s'en dire que ces temps calculés à l'avance sont sujets à la question suivante: Sont-ils représentatifs? Ordinairement ces temps sont obtenus dans un laboratoire où les conditions sont différentes de celles d'un atelier et les individus analysés sont trop peu nombreux pour représenter une population entière. De plus, ils sont rarement choisis au hasard.

LE RYTHME

En employant ces temps prédéterminés il faut présumer que le rythme de travail n'est pas personnel ou du moins qu'on peut l'imposer. Dans une expérience conduite par Barnes et Mundel, on a réalisé que plus l'opération est longue, plus la différence de temps entre les opérateurs est minime, et que plus l'opération est courte, plus la différence est marquée.

On découvre par ailleurs que les éléments d'une opération influent les uns sur les autres, qu'un élément dépend de celui qui le précède et qu'à son tour il influencera le suivant. C'est pourquoi il n'est pas justifiable de prendre ces temps prédéterminés et donnés dans des tables, de les additionner et de déterminer ainsi le temps requis pour accomplir une tâche.

En conclusion, disons que le temps requis pour accomplir une tâche dépend:

- 1—de l'individu lui-même qui l'accomplit et,
- 2—de l'ordre dans lequel les éléments d'opération apparaissent dans la tâche.

De plus, certaines expériences nous amènent à conclure que non seulement la relation des éléments varient d'un individu à l'autre mais aussi chez le même individu.

Ces temps prédéterminés peuvent quand même être d'une grande utilité pour établir des contrôles et améliorer le processus de la production, mais ce n'est pas rendre justice à l'employé que de s'en servir pour établir un système de rémunération selon la production accomplie.