

# Movement of grain to control stored-product insects and mites

## Brassage des grains entreposés pour lutter contre les insectes et acariens

N.D.G. White, D.S. Jayas and C.J. Demianyk

Volume 78, Number 2, 1997

URI: <https://id.erudit.org/iderudit/706122ar>

DOI: <https://doi.org/10.7202/706122ar>

[See table of contents](#)

### Publisher(s)

Société de protection des plantes du Québec (SPPQ)

### ISSN

0031-9511 (print)

1710-1603 (digital)

[Explore this journal](#)

### Cite this article

White, N., Jayas, D. & Demianyk, C. (1997). Movement of grain to control stored-product insects and mites. *Phytoprotection*, 78(2), 75–84. <https://doi.org/10.7202/706122ar>

### Article abstract

The movement of stored grain by auger or pneumatic conveyor was evaluated for control of stored-product insects and mites. In a pilot scale test using nine welded steel bins each holding 322 kg of wheat (*Triticum aestivum*), movement of grain using an auger in three bins caused 89% mortality of red flour beetle, *Tribolium castaneum* adults and 94% mortality of rusty grain beetle, *Cryptolestes ferrugineus* adults. Larval mortality of both species, based on grain samples placed in Berlese funnels, was 100%. Pneumatic conveyance of grain in three bins caused 100% mortality of all stages of both insects based on grain samples and grain-probe insect traps. In field tests, infested wooden bins of wheat and corn (*Zea mays*) were moved by pneumatic conveyor to a truck and then hand-poured into welded steel bins. A parallel test on wheat and corn was done using a screw auger to move the grain. Pneumatic wheat movement killed 100% of mites (*Aeroglyphus robustus*), *T. castaneum* adults and larvae, and *C. ferrugineus* adults. Mortality of *C. ferrugineus* larvae and psocids was 79% and 83%, respectively. Augering wheat killed 98% of mites, 84% *T. castaneum* adults, 70% *T. castaneum* larvae, 14% *C. ferrugineus* adults, and 0% *C. ferrugineus* larvae. Pneumatic movement of corn killed 97% *T. castaneum* adults, 72% *C. ferrugineus* adults and 100% of the fungus beetle *Cartodere constricta*. Augering corn had less effects than pneumatic movement on insect mortality. Pneumatic conveyance of grain, especially wheat, offers an effective physical control for common stored-product insects.

---

## Movement of grain to control stored-product insects and mites

Noel D.G. White<sup>1</sup>, Digvir S. Jayas<sup>2</sup>, and Colin J. Demianyk<sup>1</sup>

Received 1996-06-10; accepted 1997-03-08

---

The movement of stored grain by auger or pneumatic conveyor was evaluated for control of stored-product insects and mites. In a pilot scale test using nine welded steel bins each holding 322 kg of wheat (*Triticum aestivum*), movement of grain using an auger in three bins caused 89% mortality of red flour beetle, *Tribolium castaneum* adults and 94% mortality of rusty grain beetle, *Cryptolestes ferrugineus* adults. Larval mortality of both species, based on grain samples placed in Berlese funnels, was 100%. Pneumatic conveyance of grain in three bins caused 100% mortality of all stages of both insects based on grain samples and grain-probe insect traps. In field tests, infested wooden bins of wheat and corn (*Zea mays*) were moved by pneumatic conveyor to a truck and then hand-poured into welded steel bins. A parallel test on wheat and corn was done using a screw auger to move the grain. Pneumatic wheat movement killed 100% of mites (*Aeroglyphus robustus*), *T. castaneum* adults and larvae, and *C. ferrugineus* adults. Mortality of *C. ferrugineus* larvae and psocids was 79% and 83%, respectively. Augering wheat killed 98% of mites, 84% *T. castaneum* adults, 70% *T. castaneum* larvae, 14% *C. ferrugineus* adults, and 0% *C. ferrugineus* larvae. Pneumatic movement of corn killed 97% *T. castaneum* adults, 72% *C. ferrugineus* adults and 100% of the fungic beetle *Cartodere constricta*. Augering corn had less effects than pneumatic movement on insect mortality. Pneumatic conveyance of grain, especially wheat, offers an effective physical control for common stored-product insects.

### [Brassage des grains entreposés pour lutter contre les insectes et les acariens]

Des grains entreposés furent brassés à l'aide d'une vis sans fin ou d'un transporteur pneumatique pour déterminer les effets d'un tel procédé dans la lutte contre les insectes et les acariens. Au cours d'un essai pilote, on a utilisé neuf cellules métalliques soudées contenant chacune 322 kg de blé (*Triticum aestivum*). Dans trois cellules, on a déplacé le grain au moyen d'une vis sans fin : on a constaté un taux de mortalité de 89 % des insectes adultes pour les triboliums rouges de la farine (*Tribolium castaneum*) et de 94 % des insectes adultes pour le cucujide roux (*Cryptolestes ferrugineus*). Le taux de mortalité des larves, mesuré en plaçant des échantillons de céréales dans les entonnoirs Berlese, était de 100 %. Le déplacement pneumatique des céréales dans trois cellules a résulté en un taux de

- 
1. Agriculture and Agri-Food Canada, Cereal Research Centre, 195 Dafoe Road, Winnipeg, Manitoba, Canada R3T 2M9. Cereal Research Centre Contribution no. 1657
  2. Department of Biosystems Engineering, University of Manitoba, Winnipeg, Manitoba, Canada R3T 5V6

mortalité de 100 % (espèces d'insectes et stades de maturité confondus), que l'on a mesuré à l'aide d'une sonde à grain et de pièges à insectes. Sur le terrain, on a procédé à des essais dans des cellules en bois contenant du blé et du maïs (*Zea mays*) infestés. Le contenu des cellules a été chargé dans un camion par un transporteur pneumatique, puis transvidé à la main dans les cellules métalliques soudées. On a effectué un test parallèle sur du blé et du maïs en utilisant une vis à tarière pour déplacer les céréales. Dans le cas du blé, le déplacement pneumatique a tué 100 % des acariens (*Aeroglyphus robustus*), des *T. castaneum* adultes et larves et des *C. ferrugineus* adultes. Le taux de mortalité des larves de *C. ferrugineus* et des psocoptères était respectivement de 79 % et de 83 %. Le déplacement du blé à la vis sans fin a tué 98 % des acariens, et respectivement 84 et 70 % des adultes et des larves chez *T. castaneum*, et 14 et 0 % chez *C. ferrugineus*. Le déplacement pneumatique du maïs a détruit 97 % des *T. castaneum* adultes, 73 % des *C. ferrugineus* adultes et 100 % des *Cartodere constricta*. Le déplacement du maïs à la vis sans fin a donné une mortalité des insectes inférieure à celle obtenue avec le déplacement pneumatique. Le déplacement pneumatique des céréales, en particulier du blé, est un moyen physique efficace de lutter contre les espèces communes d'insectes infestant les produits entreposés.

## INTRODUCTION

Physical methods to control insect infestations in stored grain and flour are preferable to fumigation and insecticide application because of lack of chemical residues, safety of applicators, and minimal likelihood of the development of insect resistance (Banks and Fields 1995; Fields and Muir 1996). Transference of grain through screw augers (Muir *et al.* 1977), entoleters (Stratil *et al.* 1987), or pneumatic conveyors (Coburn *et al.* 1972; Fleurat-Lessard 1980, 1985; Green and Tyler 1966; Kirkpatrick and Cagle 1978; Sutherland *et al.* 1989) kills many insects by impact due to gravity (Banks 1987; Loschiavo 1978) or centrifugal force. Most observations related to insect mortality by pneumatic conveyance have been casual observations secondary to study of a different control technique. An exception was a commercial-scale test of ship-loading suction devices moving 15 to 37.5 t h<sup>-1</sup> of grain in which stored-product insect infestations were significantly reduced (Bahr 1990); however, this study relied on grain sampling and grain incubation and did not use insect probe traps (White *et al.* 1990).

Pneumatic grain movement is not used widely at the farm level in most countries because of high power consumption, low conveying rates, and an initial capital cost 10 to 15 times higher when compared to screw augers. Grain screw augers have a capacity about 5- to 12-fold greater than pneumatic conveyors for machines with similar inlet diameters (PAMI 1979, 1985a, b). Pneumatic conveyors also require a tractor with a power-take-off to operate, while many augers are self-contained with relatively small motors.

Pneumatic conveyors are useful in emptying granaries since they eliminate shovelling grain and most dust, are safer to operate than augers, and can transport grain greater horizontal or vertical distances than augers (PAMI 1985a, b). They may be a practical method for insect control at the farm level in conditions where insecticides or fumigants cannot be used, often because of low temperatures. Pneumatic conveyors may also be a potential alternate for control if aeration systems are not attached to granaries or winter temperatures are not low enough to rapidly kill pests (Fields 1992). The aim of this study was to quantify pest population

reduction in wheat (*Triticum aestivum* L.) and corn (*Zea mays* L.) following grain movement with an auger or by pneumatic conveyor.

## MATERIALS AND METHODS

### Equipment to move grain

The pneumatic grain conveyor was a Neuro 675 (Neuro Corp., West Chicago, IL) that operated at 1 000 rpm and had a grain inlet and outlet of 15 cm diam (Fig. 1). The inlet piping used was 7 cm diam and the rate of grain movement was about 4 t h<sup>-1</sup>. The auger used in the pilot scale study had a 5 cm diam and was 2.9 m long. The grain flow rate was 0.7 t h<sup>-1</sup>. The screw auger used in the granary study was 11 m long and 17 cm diam and operated with a 16 horsepower motor at 600 rpm. It transferred about 30 t h<sup>-1</sup>.

### Pilot scale study

Nine welded-steel bins, 168 cm high x 58 cm diam, each holding 322 kg of cleaned hard red spring wheat at 14 % moisture content, were artificially infested with mixed-age rusty grain beetle, *Cryptolestes ferrugineus* (Stephens) [Coleoptera : Cucujidae] and red flour beetle, *Tribolium castaneum* (Herbst) [Coleoptera : Tenebrionidae]. Each bin received 24 000 adults and 8 000 larvae

of *C. ferrugineus* and 25 000 adults and 1 000 mixed-age larvae of *T. castaneum*. *C. ferrugineus* cultures were maintained at 30 ± 1°C and 70 ± 5 % RH (means ± standard errors of the mean throughout text) on whole wheat plus wheat germ (95:5, wt:wt). *Tribolium castaneum* cultures were maintained on wheat flour plus brewer's yeast (95:5, wt:wt) under the same conditions. The bins were held at 25 ± 1°C and the insects were allowed to acclimatize and disperse for 2 wk.

At the beginning of the test, wheat samples of 186 g were taken from each of seven locations per bin, including below the top, and then every 24 cm lower through sampling ports covered with removable rubber septa (Fig. 2). The grain was placed in Berlese funnels for 24 h and the insects were collected in ethanol and then counted. Initially, three control bins and six treatment bins were sampled and then one insect probe trap, 3.5 cm diam x 45 cm long (Trécé Inc., Salinas, CA) was placed 5 cm below the grain surface in each bin (White *et al.* 1990). The traps were removed after 1 wk and captured insects counted.

Grain from three bins was then pneumatically transferred to three empty bins and grain from three bins was moved

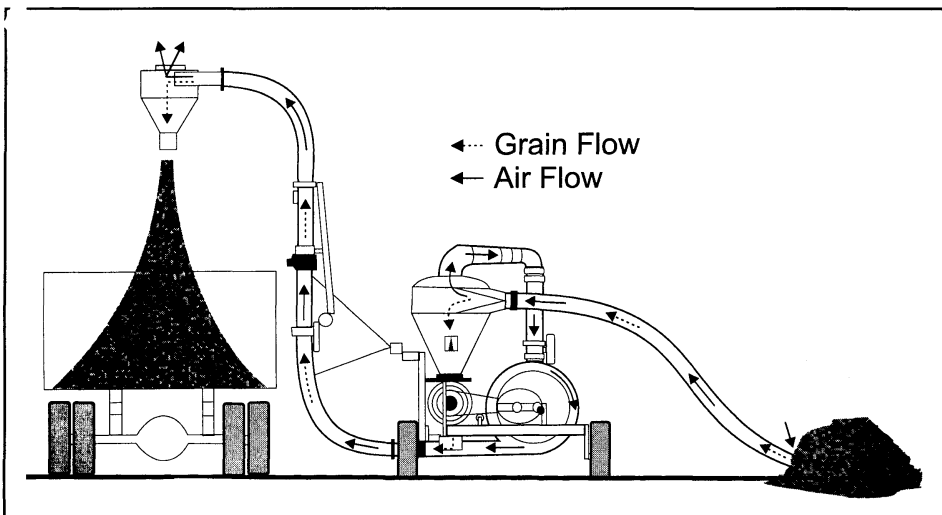

Figure 1. Schematic view showing air and grain flow through a pneumatic conveyor.

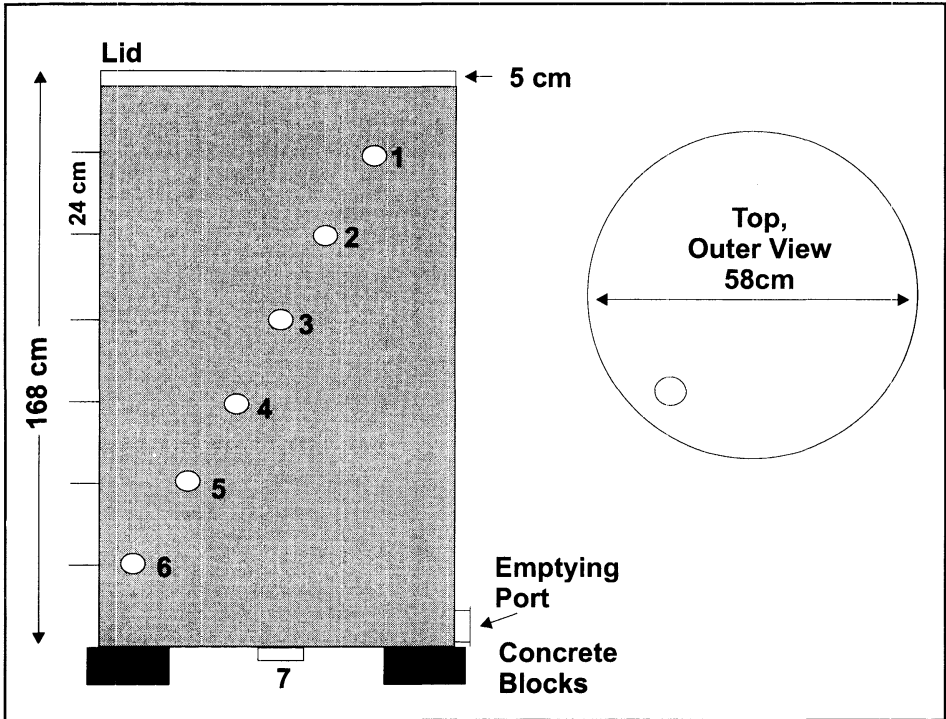

Figure 2. Schematic view, side and top, of pilot-scale steel bins each holding 322 kg of wheat and grain sampling locations.

by auger to three empty bins. The grain in the three control bins was not moved. One day after grain movement all nine bins were again sampled at seven locations per bin. Insect probe traps were placed individually in each bin and insects counted after 1 wk.

### Field study

Two bins (each 1.8 m long x 1.5 m wide x 1.3 m deep) of hard red spring wheat at  $13.2 \pm 0.1\%$  moisture content and two bins of shelled field corn at  $13.0 \pm 0.1\%$  moisture content were held in wooden granaries at Glenlea, Manitoba. The grain in all bins was infested with adults and larvae of *C. ferrugineus* and *T. castaneum* from laboratory cultures and left for 2 mo (July and August 1995).

At the end of 2 mo of storage, 200-g grain samples were then taken at each of 10 locations per bin with a torpedo probe (Sinha *et al.* 1962); five samples from the grain bulk top and five corre-

sponding samples from 1-m deep (Fig. 3). The grain was placed in Berlese funnels for 24 h and insects counted. Five insect probe traps per bin were placed in locations corresponding to grain sampling locations with the tops of the traps 1 cm below the bulk surface; they were left for 1 wk at  $20 \pm 1^\circ\text{C}$ . The insects captured were counted and recorded.

Grain from one bin of wheat was moved by pneumatic transfer to a truck and then hand-poured with pails into a galvanized metal bin (1.6 m high x 1.5 m diam). Wheat from the other bin was moved by auger to the truck and then hand-poured into another metal bin. Ten grain samples per bin were taken in a similar pattern as in Fig. 3, placed in Berlese funnels for 24 h, then the insects were counted. Five insect probe traps per bin were placed in locations corresponding to grain sampling locations with the tops of the traps 1 cm

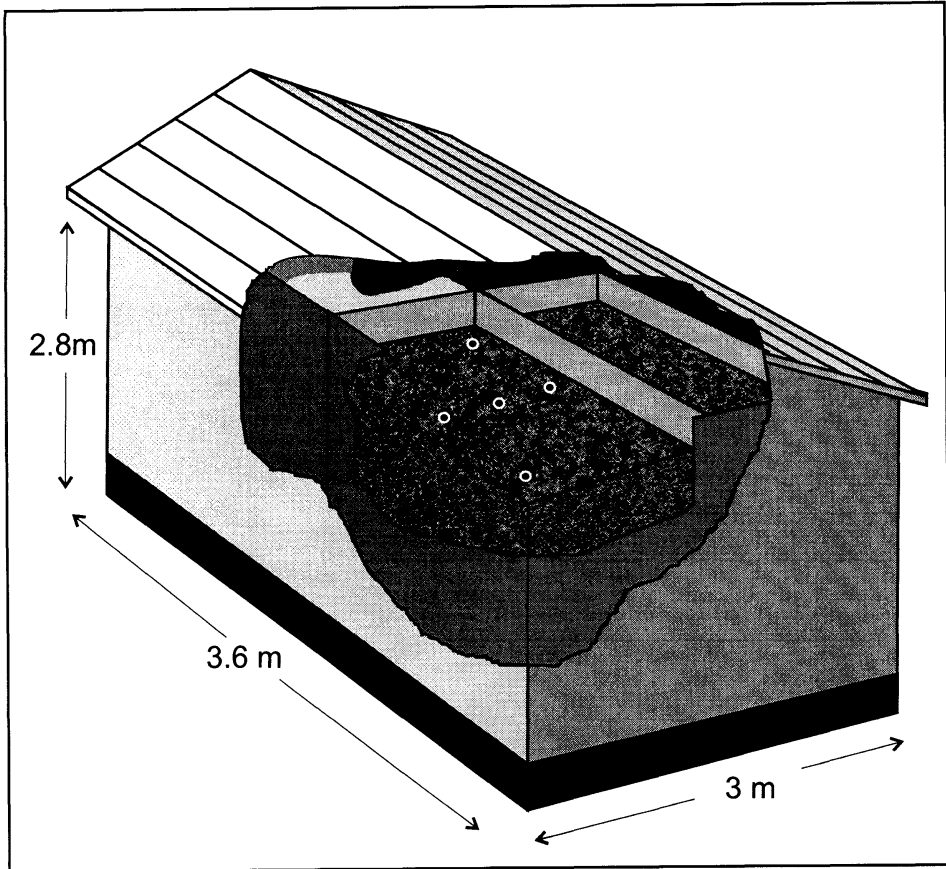

Figure 3. Schematic view of grain sampling locations (surface and 1-m deep) and insect trap locations (5) in each of two bins of wheat and two bins of shelled corn.

below the bulk surface. After 1 wk at grain temperatures of  $24 \pm 2^\circ\text{C}$ , the captured insects were counted.

The same procedure was then followed for the corn from the two bins although grain temperatures after movement were  $21 \pm 2^\circ\text{C}$ . Where appropriate, data from different treatments were compared by analysis of variance.

## RESULTS AND DISCUSSION

### Pilot scale study

There were no significant differences among the numbers of insects in the control bins at time 0 and 1 wk or be-

tween the numbers in the control bins and the initial numbers in the auger bins or the pneumatic conveyor bins that were to have grain transferred (*T. castaneum* adults:  $df = 2, 60, F = 1.19, P > 0.05$ ; *C. ferrugineus* adults:  $df = 2, 60, F = 0.78, P > 0.05$ ; *C. ferrugineus* larvae:  $df = 2, 60, F = 0.91, P > 0.05$ ). The distribution of *T. castaneum* and *C. ferrugineus* adults and larvae throughout the columns of grain was typical of that found in previous studies (White and Loschiavo 1986). *T. castaneum* adults and larvae were generally more abundant near the middle regions of the grain columns while *C. ferrugineus* adults and larvae were more abundant near the bottom regions of the column (Table 1). After grain was transferred, it was mixed

**Table 1. Mean numbers<sup>a</sup> of *Tribolium castaneum* and *Cryptolestes ferrugineus* in 186 g wheat samples from bins holding 322 kg at the beginning or end of 1 wk at 25 ± 1°C and after auger or pneumatic movement of three bins of grain to three empty bins; insect probe traps were left in the grain for 1 wk before and 1 wk after movement**

Treatment	Location	Start of experiment				End of experiment			
		<i>T. castaneum</i>		<i>C. ferrugineus</i>		<i>T. castaneum</i>		<i>C. ferrugineus</i>	
		Adults	Larvae	Adults	Larvae	Adults	Larvae	Adults	Larvae
<i>Control (no movement)</i>	1 (Top)	5 ± 1	1 ± 0	4 ± 1	1 ± 1	9 ± 3	0	5 ± 1	1 ± 0
	2	14 ± 2	0	1 ± 1	0	26 ± 10	0	1 ± 0	0
	3	25 ± 15	1 ± 0	2 ± 1	0	26 ± 8	4 ± 4	8 ± 6	6 ± 6
	4	46 ± 17	2 ± 2	12 ± 6	9 ± 5	39 ± 22	4 ± 2	17 ± 8	4 ± 4
	5	42 ± 27	11 ± 4	11 ± 4	12 ± 7	49 ± 28	15 ± 8	29 ± 16	8 ± 4
	6	38 ± 26	9 ± 5	9 ± 4	28 ± 22	37 ± 27	20 ± 12	18 ± 7	21 ± 11
	7 (Bottom)	5 ± 5	1 ± 1	80 ± 25	5 ± 3	19 ± 18	4 ± 2	11 ± 4	10 ± 4
Mean total/1302 g wheat Probe traps from 0-1 wk (n = 3)		175	25	119	55	205 2130 ± 170	47 1 ± 1	89 1005 ± 64	50 0
<i>Grain transferred by auger</i>	1 (Top)	7 ± 6	1 ± 0	21 ± 12	2 ± 0	1 ± 0	0	0	0
	2	12 ± 3	0	3 ± 3	0	2 ± 1	0	0	0
	3	9 ± 2	1 ± 1	3 ± 1	0	10 ± 5	0	0	0
	4	41 ± 6	6 ± 4	13 ± 5	7 ± 1	0	0	0	0
	5	35 ± 13	4 ± 4	16 ± 9	7 ± 5	0	0	0	0
	6	17 ± 2	9 ± 5	12 ± 1	6 ± 5	0	0	0	0
	7 (Bottom)	3 ± 2	1 ± 1	111 ± 40	4 ± 3	0	0	10 ± 5	0
Mean total/1302 g wheat Probe traps from 0-1 wk		124	22	179	26	14 16 ± 7	0 0	10 1 ± 1	0 0
<i>Grain transferred by pneumatic conveyor</i>	1 (Top)	8 ± 6	1 ± 0	15 ± 6	1 ± 0	0	0	0	0
	2	12 ± 4	0	4 ± 2	0	0	0	0	0
	3	9 ± 2	0	8 ± 6	0	0	0	0	0
	4	35 ± 7	4 ± 3	10 ± 3	7 ± 1	0	0	0	0
	5	42 ± 9	4 ± 2	13 ± 4	7 ± 2	0	0	0	0
	6	26 ± 4	6 ± 3	15 ± 2	9 ± 2	0	0	0	0
	7 (Bottom)	2 ± 1	1 ± 0	74 ± 26	4 ± 1	0	0	0	0
Mean total/1302 g wheat Probe traps from 0-1 wk		134	15	139	28	0 0	0 0	0 0	0 0

<sup>a</sup> Means ± standard errors of the means, n = 3.

uniformly distributing insect populations. Compared to unmoved grain, samples after transfer by auger had insect populations 89 % lower for *T. castaneum* adults, 94 % lower for *C. ferrugineus* adults and 100 % lower for all larvae. Grain samples transferred by pneumatic conveyor contained no live insects. Adult population reduction based on sensitive probe trap catches was over 99 % for *T. castaneum* and *C. ferrugineus* after movement by auger and 100 % for both species after pneumatic movement (Table 1). Larval reductions were high but cannot be reliably determined from probe trap catches which are biased primarily for adults (White *et al.* 1990). Also, *C. ferrugineus* larvae remain under the seed coat in the germ of grains (Rilett 1949) making grain sampling and Berlese funnel extraction the most reliable method of detection (Smith 1977).

**Granary study**

In the two wheat bins, in addition to the artificial infestation, there were low levels of other insects and large numbers of the mite, *Aeroglyphus robustus* (Banks) [Acarina : Glycyphagidae] (Sinha 1966). Mites were most dense at the top of the grain bulks (Table 2). Based

on probe trap catches, there were initially significantly more *C. ferrugineus* adults in the pneumatic bin than in the auger bin ( $df = 1, 9, F = 16.7, P < 0.05$ ) but no differences in numbers of *T. castaneum* adults. After pneumatic conveyance 100 % of *A. robustus*, *T. castaneum* adults and larvae, and *C. ferrugineus* adults were killed. Mortality in *C. ferrugineus* larvae and psocids was 79 % and 83 %, respectively.

After augering the wheat, mortality levels were 98 % for *A. robustus*, 84 % for *T. castaneum* adults, 70 % for *T. castaneum* larvae, 14 % for *C. ferrugineus* adults, and 0 % for *C. ferrugineus* larvae. There were significant differences in numbers of *T. castaneum* ( $df = 1, 9, F = 33.5, P < 0.05$ ) and *C. ferrugineus* adults ( $df = 1, 9, F = 14.7, P < 0.05$ ) in probe traps before and after pneumatic conveyance, significant differences between *T. castaneum* adults before and after augering wheat ( $df = 1, 9, F = 160.0, P < 0.05$ ), but no difference in numbers of *C. ferrugineus* larvae before and after augering ( $df = 1, 9, F = 0.01, P > 0.05$ ).

In the corn bins, *T. castaneum* ( $df = 1, 9, F = 2.61, P > 0.05$ ) and *C. ferru-*

**Table 2. Mean numbers<sup>a</sup> of insects or mites in 200 g samples or 1-wk probe trap catches in wheat stored in wooden bins (A) before and (B) after transference by pneumatic conveyor or auger**

Method	Location	<i>T. castaneum</i>		<i>C. ferrugineus</i>		<i>Aeroglyphus robustus</i>	<i>Psocids</i>
		Adults	Larvae	Adults	Larvae		
<i>A Before transference</i>							
Pneumatic bin	Top	1 ± 0.4	2 ± 1	0.2 ± 0.2	0.4 ± 0.4	1800 ± 203	3.6 ± 2
	1-m	0	0.6 ± 0.2	0	2.4 ± 1	240 ± 52	3.4 ± 1
	Probe trap <sup>b</sup>	64 ± 17	0	10.3 ± 4	0	0	0
Auger bin	Top	0.8 ± 0.4	1.2 ± 0.6	0	0	2600 ± 610	0.6 ± 0.6
	1-m	0	0.8 ± 0.6	0	0.6 ± 0.3	220 ± 75	0.4 ± 0.2
	Probe trap <sup>b</sup>	48 ± 4	0	4.3 ± 0.3	0	0	0
<i>B After transference</i>							
Pneumatic bin	Top	0	0	0	0.4 ± 0.2	0	0.6 ± 0.3
	1-m	0	0	0	0.2 ± 0.2	0	0.6 ± 0.2
	Probe trap <sup>c</sup>	0	0	0	0	0	0
Auger bin	Top	0	0	0.2 ± 0.2	2 ± 0.5	44 ± 21	0.8 ± 0.4
	1-m	0	0.6 ± 0.2	0	2 ± 1.3	12 ± 4	0.4 ± 0.4
	Probe trap <sup>c</sup>	8 ± 1	0.2 ± 0.2	5 ± 2	0	0	0

<sup>a</sup> Means ± standard errors of the means,  $n = 5$ .

<sup>b</sup> Grain temperature 20°C prior to moving.

<sup>c</sup> Grain temperature 24°C after moving.



**Table 3. Mean numbers<sup>a</sup> of insects in 200 g samples or 1-wk probe trap catches in shelled corn in wooden bins before (A) and after (B) transference by pneumatic conveyor or auger**

Method	Location	<i>Tribolium castaneum</i>		<i>Cryptolestes ferrugineus</i>		<i>Cartodere constricta</i>
		Adults	Larvae	Adults	Larvae	Adults
<i>A Before transference</i>						
Pneumatic bin	Top	0.2 ± 0.2	0	0.4 ± 0.4	0	0
	1-m	0	0.2 ± 0.2	0	0.2 ± 0.2	0
	Probe traps <sup>b</sup>	6 ± 3	0	5 ± 3	0	16 ± 3
Auger bin	Top	3 ± 1	3 ± 2	3 ± 2	3 ± 1	1.2 ± 0.4
	1-m	0	0.8 ± 0.4	1 ± 0.3	1.2 ± 0.5	0
	Probe traps <sup>b</sup>	117 ± 88	13 ± 9	61 ± 58	0	18 ± 10
<i>B After transference</i>						
Pneumatic bin	Top	0	0	0	0.2 ± 0.2	0
	1-m	0	0	0	0.4 ± 0.2	0
	Probe traps <sup>c</sup>	0.2 ± 0.2	0	1.4 ± 0.6	0	0
Auger bin	Top	2 ± 0.4	2 ± 0.5	2 ± 1.2	4 ± 2	0
	1-m	3 ± 1	1.4 ± 0.5	2 ± 0.7	4 ± 1	0
	Probe traps <sup>c</sup>	298 ± 96	0.2 ± 0.2	22 ± 8	0	0

<sup>a</sup> Means ± standard errors of the means,  $n = 5$ .

<sup>b</sup> Grain temperature 20°C prior to moving.

<sup>c</sup> Grain temperature 21°C after moving.

*gineus* adults ( $df = 1, 9, F = 0.54, P > 0.05$ ) in the auger bin were not reduced by grain movement but they were reduced in the pneumatic bin (*T. castaneum*:  $df = 1, 9, F = 9.5, P < 0.05$ ; *C. ferrugineus*:  $df = 1, 9, F = 8.56, P < 0.05$ ) (Table 3). However, based on mean probe trap catches after pneumatic conveyance of corn, mortality levels were 97 % for *T. castaneum* adults, 70 % for *C. ferrugineus* adults and 100 % for fungus beetle *Cartodere constricta* (Gyllenhal) [Coleoptera : Lathridiidae] adults. After augering, mortality was 0 % for *T. castaneum* adults, 98 % for *T. castaneum* larvae, 64 % for *C. ferrugineus* adults and 100 % for *C. constricta* adults.

In all cases, augering of grain had considerably less effect on insect populations than pneumatic conveyance. The latter can offer good control in wheat but is less effective in shelled corn with its larger kernels and larger quantities of grain dust and broken particles. *T. castaneum* is much more susceptible to pneumatic conveyance than *C. ferrugineus* (Bahr 1990) probably because of its larger size and free-living larvae. *C. ferrugineus* is small and many larvae are protected within

the germ of kernels. Nonetheless, reductions of 99-100 % were obtained for all life stages of *T. castaneum* and *C. ferrugineus* following pneumatic movement of wheat. *C. ferrugineus* is the main insect pest of stored grain in western Canada (Madrid *et al.* 1990); it can survive temperatures down to -17°C for short periods (Fields 1990) and is found in grain shipments throughout the year (C. Van Natto, Canadian Grain Commission, personal communication). Fumigation of grain with the only registered synthetic fumigant, hydrogen phosphide, is not effective at temperatures below 10°C (Anonymous 1989) and an alternative physical control such as pneumatic conveyance offers an effective option both for on-farm disinfestation, as well as for rail car disinfestation.

## ACKNOWLEDGEMENTS

We thank Dave Strong, Sean Lepper, and Kelly Shideler for technical assistance and R. Sims for preparing the figures.

## REFERENCES

- Anonymous.** 1989. Stored grain pests. Supplement to the official grain inspectors' manual. Office of the Chief Grain Inspector, Canadian Grain Commission, Winnipeg, Manitoba, Canada. 43 pp.
- Bahr, I.** 1990. Reduction of stored product insects during pneumatic unloading of ship cargoes. Pages 1135-1144 in F. Fleurat-Lessard and P. Ducom (eds.), Proceedings 5<sup>th</sup> International Working Conference on Stored-Products Protection, Bordeaux, France.
- Banks, H.J.** 1987. Impact, physical removal and exclusion for insect control in stored products. Pages 165-184 in E. Donahaye and S. Navarro (eds.), Proceedings 4<sup>th</sup> International Working Conference on Stored-Products Protection, Tel Aviv, Israel.
- Banks, H.J., and P.G. Fields.** 1995. Physical methods for insect control in stored-grain ecosystems. Pages 353-404 in D.S. Jayas, N.D.G. White, and W.E. Muir (eds.), Stored grain ecosystems. Marcel Dekker, Inc., New York.
- Cogburn, R.R., E.W. Tilton, and J.H. Brower.** 1972. Bulk-grain gamma irradiation for control of insects infesting wheat. J. Econ. Entomol. 65: 818-821.
- Fields, P.G.** 1990. The cold-hardiness of *Cryptolestes ferrugineus* and the use of ice nucleation active bacteria as a cold synergist. Pages 1183-1191 in F. Fleurat-Lessard and P. Ducom (eds.), Proceedings 5<sup>th</sup> International Working Conference on Stored-Products Protection, Bordeaux, France.
- Fields, P.G.** 1992. The control of stored product insects and mites with extreme temperatures. J. Stored Prod. Res. 28: 89-118.
- Fields, P.G., and W.E. Muir.** 1996. Physical control. Pages 195-221 in B. Subramanyam and D.W. Hagstrum (eds.), Integrated management of insects in stored products. Marcel Dekker, Inc., New York.
- Fleurat-Lessard, F.** 1980. Lutte physique par l'air chaud ou les hautes fréquences contre les insectes des grains et des produits céréaliers. Bull. Tech. Inf. Céréales 349: 345-352.
- Fleurat-Lessard, F.** 1985. Les traitements thermiques de désinfestation des céréales et des produits céréaliers: possibilité d'utilisation pratique et domaine d'application. Bulletin OEPP 15: 109-118.
- Green, A.A., and P.S. Tyler.** 1966. A field comparison of malathion, dichlorvos and fenitrothion for control of *Oryzaephilus surinamensis* (L.) (Coleoptera: Silvanidae) infesting stored barley. J. Stored Prod. Res. 1: 273-285.
- Kirkpatrick, R.L., and A. Cagle.** 1978. Controlling insects in bulk wheat with infrared radiation. J. Kansas Entomol. Soc. 51: 386-393.
- Loschiavo, S.R.** 1978. Effect of disturbance of wheat on four species of stored-product insects. J. Econ. Entomol. 71: 888-893.
- Madrid, F.J., N.D.G. White, and S.R. Loschiavo.** 1990. Insects in stored cereals, and their association with farming practices in southern Manitoba. Can. Entomol. 122: 515-523.
- Muir, W.E., G. Yaciuk, and R.N. Sinha.** 1977. Effects on temperature and insect and mite population of turning and transferring farm-stored wheat. Can. Agric. Eng. 19: 25-28.
- PAMI.** 1979. Nuro 675 pneumatic grain conveyor. PAMI evaluation report 133. Prairie Agricultural Machinery Institute, Portage la Prairie, Manitoba, Canada.
- PAMI.** 1985a. Kongskilde Suc 500 TR2 suction blower. PAMI evaluation report 439. Prairie Agricultural Machinery Institute, Portage la Prairie, Manitoba, Canada.
- PAMI.** 1985b. Conveyair I pneumatic grain conveyor. PAMI evaluation report 440. Prairie Agricultural Machinery Institute, Portage la Prairie, Manitoba, Canada.
- Rilett, R.O.** 1949. The biology of *Laemophloeus ferrugineus* (Steph.). Can. J. Res. D27: 112-148.
- Sinha, R.N.** 1966. *Aeroglyphus robustus*, a pest of stored grain. J. Econ. Entomol. 59: 686-688.
- Sinha, R.N., E.A.R. Liscombe, and H.A.H. Wallace.** 1962. Infestation of mites, insects and microorganisms in a large wheat bulk after prolonged storage. Can. Entomol. 94: 542-555.
- Smith, L.B.** 1977. Efficiency of Berlese-Tullgren funnels for removal of the rusty grain beetle, *Cryptolestes ferrugineus*, from wheat samples. Can. Entomol. 109: 503-509.
- Stratil, H., R. Wohlgemuth, H. Bolbing, and H. Zwengelberg.** 1987. Optimierung des Prallmaschinenverfahrens zum Abtöten und Entfernen von vorratsschädlichen Insekten aus Nahrungsmitteln unter besonderer Berücksichtigung der Qualität des Mahlerzeugnisse. Getreide Mehl Brot 41: 294-302.
- Sutherland, J.W., P.W. Fricke, and R.J. Hill.** 1989. The entomological and thermodynamic performance of pneumatic conveyor wheat disinfectors using heated air. J. Agric. Eng. Res. 44: 113-124.

**White, N.D.G., and S.R. Loschiavo. 1986.** Effects of insect density, trap depth, and attractants on trapping *Tribolium castaneum* (Coleoptera: Tenebrionidae) and *Cryptolestes ferrugineus* (Coleoptera: Cucujidae) in stored wheat. J. Econ. Entomol. 79: 1111-1117.

**White, N.D.G., R.T. Arbogast, P.G. Fields, R.C. Hillmann, S.R. Loschiavo, Bh. Subramanyam, J.E. Throne, and V.F. Wright. 1990.** The development and use of pitfall and probe traps for capturing insects in stored grain. J. Kansas Entomol. Soc. 63: 506-525.